



OWNER'S MANUAL

930™ AND 935™
AUTOLOADING
SHOTGUN

IMPORTANT "SAFETY WARNINGS" - NOTE THE SYMBOL 

THESE SAFETY WARNINGS ARE FOR YOUR PROTECTION AS WELL AS THE SAFETY OF OTHERS. DISREGARDING INFORMATION IN THIS MANUAL COULD RESULT IN SERIOUS INJURY OR DEATH TO YOU OR THOSE AROUND YOU.



Do not attempt to load, handle or use your Mossberg firearm until you read and understand the information contained in this owner's manual. Before handling your firearm, you should learn how it operates and how to maintain it. This includes knowing its basic parts, how the manual safety and other safety features operate, how to safely open and close the action and how to safely load and unload ammunition from the firearm. Improper use and handling is dangerous and could cause serious injury or death to you or those around you. All users of the firearm must become thoroughly familiar with the instructions in this manual.



Be certain this owner's manual is available for reference and is kept with this firearm if transferred to another party. If this manual is lost or misplaced, contact the Product Service Center for a free replacement copy. A free copy of the manual can also be downloaded from Mossberg.com.



After performing any work on your firearm such as cleaning, adjustments, disassembly or installation of any accessory, the firearm should be re-checked for proper functioning before firing live ammunition.



Firearms are complex mechanisms. Any modification, alteration, or improper fitting of parts may result in a dangerous malfunction, damage to the firearm, and could cause serious injury or death to you or those around you. The firearm's owner must accept full responsibility for the correct reassembly and functioning of the firearm after any disassembly or replacement of parts.



If you do not understand any of the material in this manual or have any questions, contact the Product Service Center or a qualified gunsmith.

O.F. MOSSBERG & SONS, INC.

P.O. BOX 497 • 7 GRASSO AVENUE, NORTH HAVEN, CONNECTICUT 06473
PHONE (203) 230-5300 FAX (203) 230-5420
www.mossberg.com

Safety and safe firearms handling is everyone's responsibility.



As the owner of a firearm, you must undertake the full-time responsibility of safe firearms handling for your own safety and the safety of those around you:

- Keep all firearms and ammunition out of the reach of children.
- Store your firearms and ammunition separately.
- Never store a loaded firearm.
- Never leave a loaded firearm unattended.
- Never transport a loaded firearm in a vehicle.
- Unload your firearm when you have stopped shooting and when you have to climb a tree, fence, cross a slippery surface or have to transport it in a vehicle.
- The safety should remain fully in the “ON” (SAFE) position and the firearm unloaded at all times until you are in a place where it is safe to shoot, keeping your finger off the trigger and outside of the trigger guard until you are aiming at the intended target and have decided to fire.
- Never shoot at water, rocks or any hard surface. Shots may glance off such surfaces and cause injuries.
- Do not use alcohol or drugs before or while handling firearms.
- Do not touch the trigger while the safety is being engaged or disengaged.



Always point the muzzle of your firearm in a safe direction, regardless of whether the firearm is loaded or unloaded. You should become thoroughly familiar with the function and operation of this firearm and the instructions supplied with it.



Always treat every firearm as if it is loaded. Give your firearm to someone with the action open (bolt fully rearward), and the safety fully in the “ON” (SAFE) position. Insist on the same procedure when receiving a firearm from someone else. Learn the location of all the safety features of your firearm and how they operate.



Always wear eye and ear protection when shooting. Shooting without proper ear protection can cause hearing damage. The use of eye protection during any type of shooting is important to protect your vision.



When using a firearm with mounted optics, maintain an adequate distance between the rear of the scope and your face at all times. Be certain the scope installation does not interfere with access to, or the proper functioning of the safety.



We specifically disclaim any responsibility for damage or injury whatsoever occurring in connection with, or as a result of, the use of faulty, or non-SAAMI standard, or “remanufactured” or hand-loaded (reloaded) ammunition. Additionally, we disclaim any responsibility for damage or injury which results from any modifications or changes that are not a part of the firearm as delivered from the factory.



Learn to clean your firearm thoroughly and make certain no oil, grease or other materials are blocking the barrel. Obstructions of any kind can cause damage to the firearm and could cause serious injury or death to you or those around you.

Practice proper firearm maintenance and safety. Make sure all exposed metal surfaces are coated with a thin film of oil, especially after being exposed to damp weather. (See “Cleaning and Lubrication” section of this manual) Do not plug the barrel or store in a fabric-lined case, which will absorb lubricants from the firearm. Before using after storage, follow complete instructions stated in this manual for re-familiarization with the firearm. A thorough inspection and function test should be performed before going into the field. Have your firearm periodically checked by a qualified gunsmith.

A note about the warnings and information contained in this Manual:

We strongly suggest that you check with your local licensed retailer or state police for additional information concerning firearms ownership, or hunting or target shooting rules that may be required by local law or regulation. Since such rules and regulations are subject to change, local authorities are in the best position to advise you on such matters.

TABLE OF CONTENTS

	Page
The Mechanical Safety	4
The Cocking Indicator	5
Unpacking Your Firearm	6
To Lock Action Open and Remove Chamber Plug	6-7
Closing the Action	7
Removing the Magazine Plug (Non SPX Models)	7
Installing the Magazine Plug	8
Magazine Capacity	8
Loading the Firearm	8-9
Loading the Magazine	10
Firing	11
Unloading the Firearm	12
Disassembly	13-16
Cleaning and Lubrication	17-18
Re-Assembly	19-21
Function Testing	22
Sight Adjustments	23-24
Stock Spacer System	25
Choke Tubes	26-27
Service Instructions	28
Warranty Information	29
Parts List	30
Exploded View	31
Notes	32-35
<i>The Basic Rules of Safe Firearms Handling</i>	Back Cover

OPERATING INSTRUCTIONS



Read and understand this entire manual and its safety warnings before handling this firearm.

MECHANICAL SAFETY

The safety button is located on the top rear portion of the receiver (Figure 1) and must be manually moved to the desired position by the shooter.

To put the safety in the “ON” (SAFE) position, the safety button must be moved fully rearward into the safety detent. The button will now cover the red dot. The red dot is a training aid used only to show the direction of the “ON” (SAFE) position and should not be used as an indicator that the safety is “ON” or “OFF.” Moving the safety button forward toward the muzzle of the firearm will put the safety in the “OFF” (FIRE) position.



Remember, a firearm’s manual safety is a mechanical device which can never replace safe firearm handling practices.



Never rely on any mechanical mechanism or safety device to prevent the dangers of careless handling or pointing a firearm in an unsafe direction.

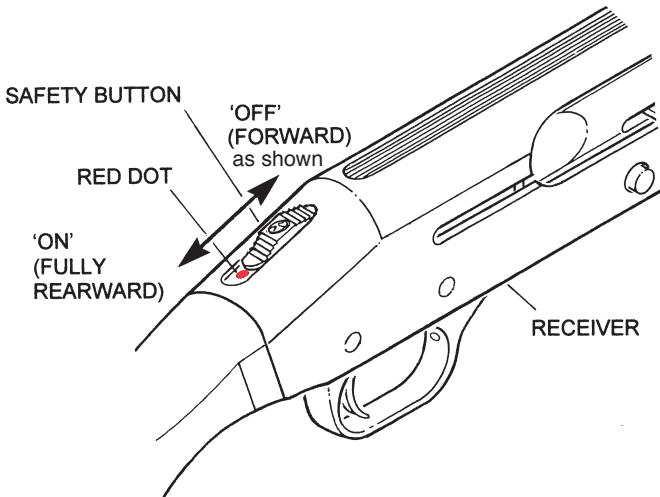

Figure 1

COCKING INDICATOR

Your firearm is equipped with a cocking indicator located in the forward section of the trigger guard (Figure 2). The cocking indicator allows the shooter to know whether or not the firearm is cocked. When the firearm is cocked (ready to fire), the indicator will protrude into the trigger guard. The cocking indicator is an automatic device; it cannot be manually activated or deactivated.



The cocking indicator is not a safety and does not indicate whether or not a cartridge is in the chamber. You must visually and physically inspect the chamber to determine if the firearm is loaded.



Remember, the firearm's cocking indicator is a mechanical device which can never replace safe firearm handling practices.



Never rely on any mechanical mechanism or safety device to prevent the dangers of careless handling or pointing a firearm in an unsafe direction.

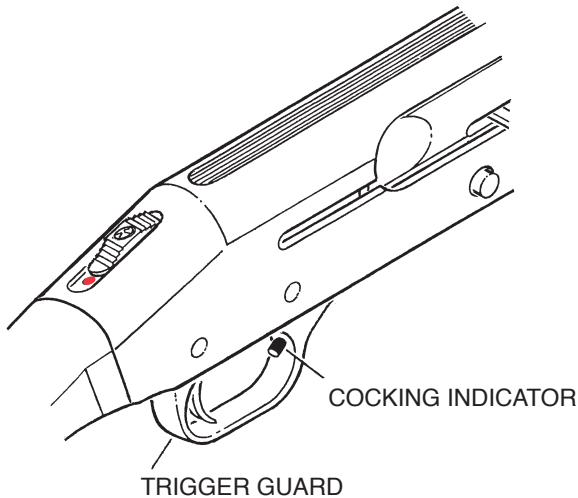

Figure 2

UNPACKING YOUR FIREARM

Your firearm is shipped from the factory fully assembled. Before using this firearm, gently tug outward on the operating handle to ensure it is securely engaged in the bolt. If the operating handle should come out of the bolt, please refer to the **Action Reassembly** instructions. The operating handle must be properly installed prior to use. A bright orange chamber plug has been inserted in the chamber (Figure 3) as an aide to ensure that the chamber is unloaded. You must remove this plug prior to use.

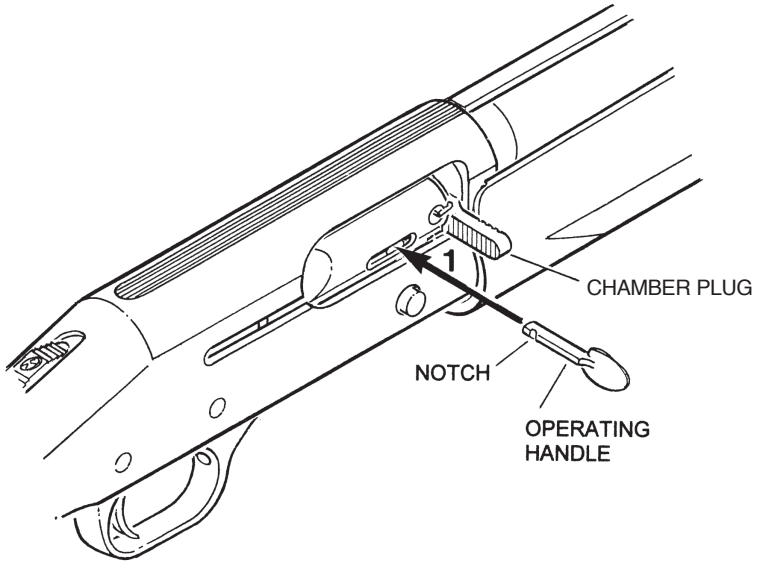

Figure 3

TO LOCK THE ACTION OPEN AND REMOVE THE CHAMBER PLUG

1. With the safety button fully rearward in the “ON” (SAFE) position, and the muzzle pointed in a safe direction, hold the firearm in your left hand by the forearm, and grasp the operating handle with your right hand. (Figure 4).
2. Pull the operating handle fully rearward in one quick motion. When released, the action will move slightly forward (towards the muzzle) and lock in the open position.
3. Remove the chamber plug from the chamber. It is recommended that the chamber plug be reinstalled when the firearm is not in use as an added measure of safety to indicate the chamber is unloaded.



Check to be sure the firearm is unloaded by visually and physically checking the chamber, elevator, and magazine tube. Make certain that the safety button is fully rearward in the “ON” (SAFE) position (Figure 1).

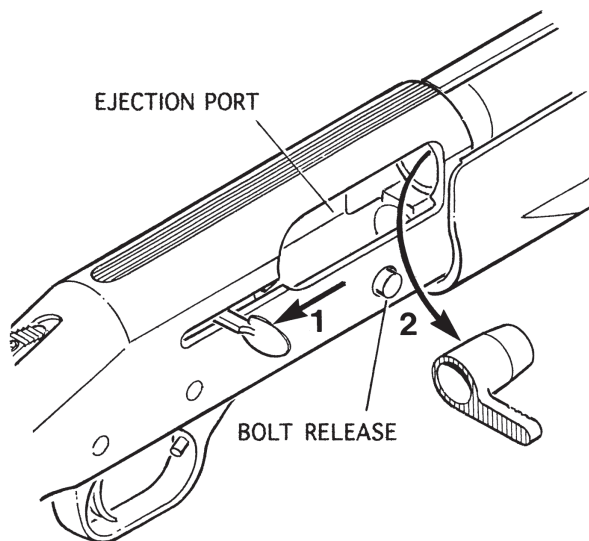

Figure 4



The bolt is always under spring pressure. When the bolt release is pushed with the bolt locked rearward, the bolt is driven forward toward the muzzle with considerable force. Do not have fingers or other objects in the ejection port or near the operating handle.



Visually and physically inspect the chamber and bore of the barrel to make certain it is free of any obstructions, excessive oil or grease. If you are unable to remove any obstruction, bring the firearm to a qualified gunsmith or send it to a factory authorized Product Service Center. Obstructions of any kind can result in damage to the firearm and/or personal injury or death to you or those around you when the firearm is fired.

CLOSING THE ACTION



Keep fingers clear of the operating handle and the ejection port when closing the action. (Figure 4)

With the safety button fully rearward in the “ON” (SAFE) position, and the muzzle pointed in a safe direction, press the bolt release until the action releases (Figure 4).

REMOVING THE MAGAZINE PLUG (NON SPX MODELS)



Be sure the firearm is unloaded by visually and physically checking the chamber, elevator, and magazine tube. Make certain that the safety button is fully rearward in the “ON” (SAFE) position before performing any assembly or disassembly procedure.

Unscrew and remove the magazine cap (Figure 9). Grasp the barrel and forearm to prevent them from sliding forward. Do not place your hand over the muzzle at any time. Point the muzzle downward and shake the firearm in an up and down motion until the wooden dowel falls through the opening at the end of the magazine tube.

INSTALLING THE MAGAZINE PLUG



Be sure the firearm is unloaded by visually and physically checking the chamber, elevator, and magazine tube. Make certain that the safety button is fully rearward in the “ON” (SAFE) position before performing any assembly or disassembly procedure.

Unscrew and remove the magazine cap (Figure 9), insert either end of the wooden dowel at the end of the magazine tube, inside the coils of the magazine spring. Replace the magazine cap finger tight only. Do not use pliers or a wrench to tighten the magazine cap.

MAGAZINE CAPACITY

930™ Models: Five (5) 2 3/4" or 3" cartridges (four (4) in the magazine tube, plus one (1) in the chamber). Depending upon tolerance variations, total capacity may be reduced by one cartridge.

930 SPX: Eight (8) 2 3/4" cartridges (seven (7) in the magazine tube, plus one (1) in the chamber), or seven (7) 3" cartridges (six (6) in the magazine tube plus one (1) in the chamber). Depending upon tolerance variations, total capacity may be reduced by one cartridge.

935™ Models: Five (5) 2 3/4" or 3" cartridges (four (4) in the magazine tube, plus one (1) in the chamber), or four (4) 3 1/2" cartridges (three (3) in the magazine tube, plus one (1) in the chamber). Depending upon tolerance variations, total capacity may be reduced by one cartridge.

MAGAZINE PLUG – You are responsible for complying with all laws regarding magazine capacity. To comply with U.S. migratory bird laws, your firearm was shipped with a wooden dowel inserted into the magazine tube which limits magazine capacity to two (2) shells. (930 SPX models do not include the wooden dowel)

LOADING THE FIREARM

930™ Models: are designed to fire 12 gauge 2 3/4" factory loaded cartridges and 3" factory loaded magnum cartridges.

935™ Models: are designed to fire 12 gauge 2 3/4" (1 1/4 oz Heavy Field minimum), 3" or 3 1/2" factory loaded cartridges only. Do not fire slugs of any type (single projectile ammunition) through the overbored **935™** Accu-Mag barrel. This barrel is designed to shoot lead or steel pellet shot only. Use only **935™** barrels designated specifically for slug shooting.

Fully rifled barrels deliver best accuracy with sabot style slugs. “Rifled” slugs and shot are not recommended for use in rifled barrels.



Before loading, move the safety button fully rearward to the “ON” (SAFE) position (Figure 1).



During loading, never allow fingers or any other objects to contact the trigger. Keep the muzzle pointed in a safe direction at all times.



Do not load the firearm until ready for use! Unload the firearm when shooting has been completed! The safety button should always be fully rearward in the "ON" (SAFE) position whether or not the firearm is loaded.



Inspect the chamber and bore of the barrel for any obstruction, excessive oil or grease. (The chamber is the rear portion of the barrel where the cartridge will be inserted.) Obstructions of any kind can result in damage to the firearm and/or serious injury or death to you or those around you when the firearm is fired.



Check to be certain that the ammunition selected is the same type of cartridge as designated on the barrel of the firearm. Failure to use correct ammunition can cause damage to your firearm and could cause serious injury or death to you or those around you.

1. Open the action by pulling the operating handle completely rearward until it locks in the open position. (Figure 5)
2. Load the first cartridge through the ejection port located on the right side of the receiver. The cartridge can be inserted directly into the chamber or placed on top of the elevator (Figure 5).



Because the bolt is under considerable spring pressure, keep fingers clear of the operating handle and the ejection port when closing the action.

3. With the safety button fully rearward in the "ON" (SAFE) position, and the muzzle pointed in a safe direction, press the bolt release until the action releases (Figure 5).
4. The action will close under spring force, chambering a live cartridge. **Be sure to keep fingers and other objects out of the ejection port!**



The firearm is now loaded and will fire if the safety is moved to the "OFF" (FIRE) position and the trigger is pulled! The safety button (Figure 1) should be kept fully rearward in the "ON" (SAFE) position until you are on target and have actually decided to fire. Keep the muzzle pointed in a safe direction at all times, and your fingers and any other objects away from the trigger area.

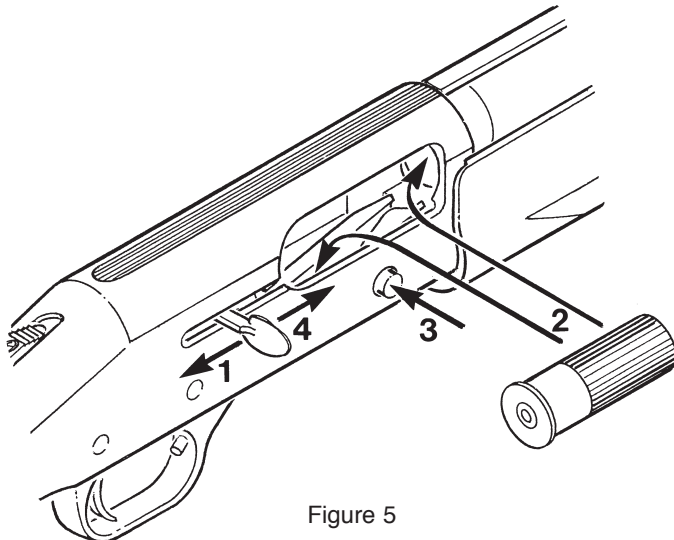

Figure 5

LOADING THE MAGAZINE



With the safety button fully rearward in the “ON” (SAFE) position, and the bolt in the forward (closed) position, hold the firearm with the bottom of the receiver facing upward. **Keep the muzzle pointed in a safe direction at all times.**

1. Carefully push the cartridge into the loading port, depressing the elevator (Figure 6). This will expose the magazine tube opening within the receiver.

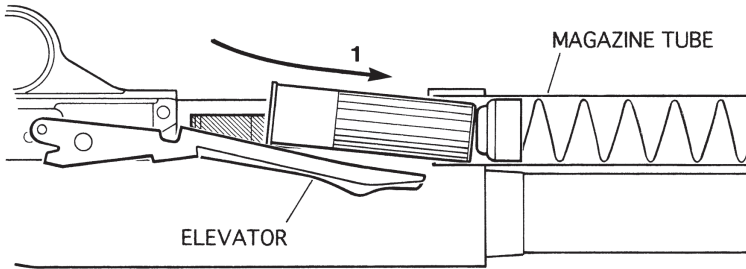

Figure 6

2. Continue carefully pushing the cartridge into the magazine tube until the rim of the cartridge is past the shell stop (Figure 7). The shell stop will “snap” over the rim of the cartridge. Repeat this sequence to load each additional cartridge.

If the cartridge is not pushed all the way into the magazine tube, it will pop back out on the opposite side of the elevator. If this should occur, while keeping the muzzle pointed in a safe direction, simply open the action by pulling the operating handle rearward, ejecting the cartridge from the chamber. Releasing the operating handle will allow the action to close, automatically feeding the “misloaded” cartridge into the chamber.



The firearm is now loaded and will fire if the safety is moved to the “OFF” (FIRE) position and the trigger is pulled.

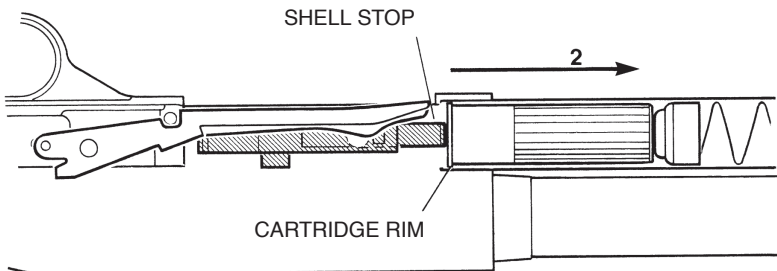

Figure 7

FIRING



Discharging firearms in poorly ventilated areas, cleaning firearms, and/or handling ammunition may result in exposure to lead and other substances known to cause birth defects, reproductive harm, and/or other serious physical injury. Have adequate ventilation at all times. Wash hands, face and clothing thoroughly after exposure.



During firing, the operating handle travels rearward with considerable force and speed. Do not place hands or other objects in its path.

With the muzzle pointed in a safe direction and the firearm held in the proper firing position, move the safety button fully forward to the “OFF” (FIRE) position. Pulling the trigger through its full travel to the rear will fire the firearm. Ensure the muzzle is pointed in a safe direction before placing your finger on the trigger.



After firing, the empty cartridge will be automatically ejected through the ejection port. Be sure all observers are clear of the path of ejection, as the empty cartridges are thrown out with considerable force and could cause injury.



This firearm automatically feeds the next live cartridge from the magazine tube into the chamber each time the firearm is fired, until all cartridges in the magazine tube are fired. You should be aware that no mechanical force on the part of the user is needed in this process and you should be alert to the fact that the chamber is loaded for you and the firearm is capable of firing again if the trigger is pulled.



This firearm is designed so that when all cartridges have been fired, the bolt will automatically lock rearward in the open position. You should never use this feature as a guide for determining if the firearm is empty! Always visually and physically inspect the chamber, elevator, and magazine tube for the presence of ammunition to ensure the firearm is completely unloaded.



Should any cartridge fail to fire, keep the muzzle pointed in a safe direction for at least (30) seconds in case the cartridge is a “hangfire” (delayed firing of the cartridge after being struck by the firing pin). Move the safety button fully rearward to the “ON” (SAFE) position. Then pull the operating handle fully rearward to extract and eject the misfired cartridge. Segregate the misfired cartridge from other ammunition. Do not attempt to refire a misfired cartridge.



If at any time during firing, the sound of any cartridge is noticeably louder or softer than the previous cartridges fired, **STOP!** Do not load or fire additional cartridges. Move the safety button fully rearward to the “ON” (SAFE) position. Keep the muzzle pointed in a safe direction. Safely unload the firearm. Check to be sure the firearm is unloaded by visually and physically checking the chamber, elevator and magazine tube. Inspect the firearm for possible damage or obstructions in the chamber or bore. (The bore is the inside surface of the barrel.) Firing the firearm with a bore obstruction can cause damage to the firearm and could result in serious injury or death to you or those around you.

UNLOADING THE FIREARM



Move the safety button fully rearward to the “ON” (SAFE) position and keep the muzzle pointed in a safe direction at all times. At no time during unloading should you allow your fingers or any other object to touch the trigger.

1. First, remove the cartridges from the magazine tube. With the safety button fully rearward in the “ON” (SAFE) position, turn the firearm so that the trigger guard is facing upward (Figure 8), keeping the muzzle pointed in a safe direction.
2. Depress the elevator.
3. While holding the elevator down with your thumb, press and release the bolt release (Figure 4). This will release one cartridge from the magazine tube under spring pressure.
4. Repeat this procedure until the magazine tube is empty.
5. With the magazine tube empty, pull the operating handle fully rearward. This will eject the cartridge from the chamber of the firearm and lock the action in the “OPEN” position.



Visually and physically inspect the chamber, elevator, and magazine tube to be certain the firearm is completely unloaded.

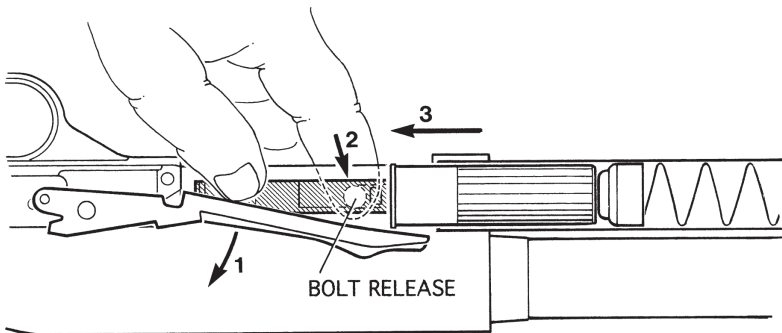

Figure 8

DISASSEMBLY



Move the safety button fully rearward to the “ON” (SAFE) position and visually and physically check the chamber, elevator, and magazine tube to be certain the firearm is unloaded before disassembling the firearm. Wear eye protection during disassembly and cleaning to protect your eyes from oil spatter or spring loaded components.

For a detailed instructional video on how to disassemble, clean and re-assemble your Mossberg 930 firearm presented by Jerry Miculek go to www.mossberg.com/mossberg-930-complete-cleaning-and-disassembly-with-jerry-miculek/.

BARREL REMOVAL

The action must be in the open position (bolt fully rearward). (See “To Lock The Action Open” section.)

1. Unscrew the magazine cap (Figure 9).
2. Slide forearm forward.
3. Pull the barrel forward, free of the receiver and magazine tube.
4. While holding the operating handle, press the bolt release. Allow the action to come slowly forward.

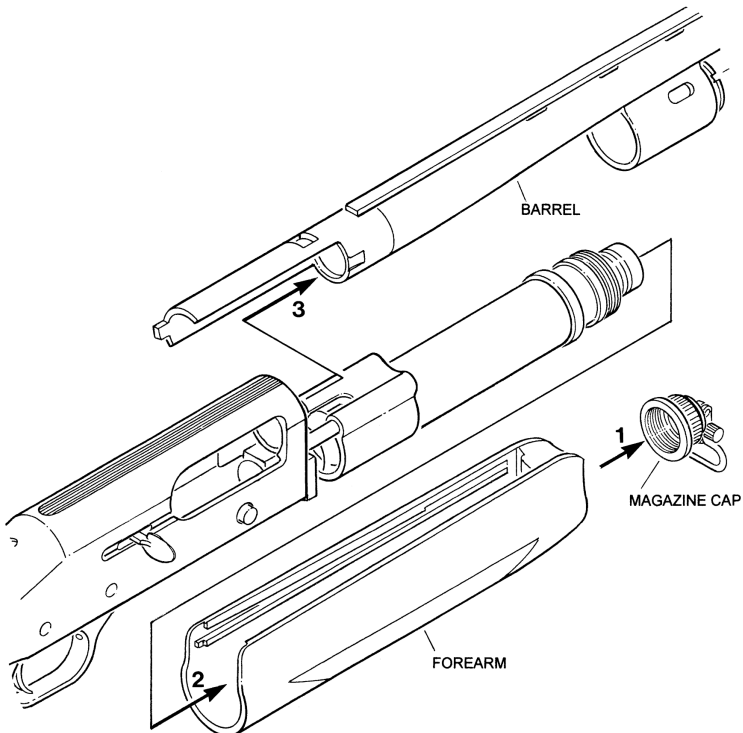
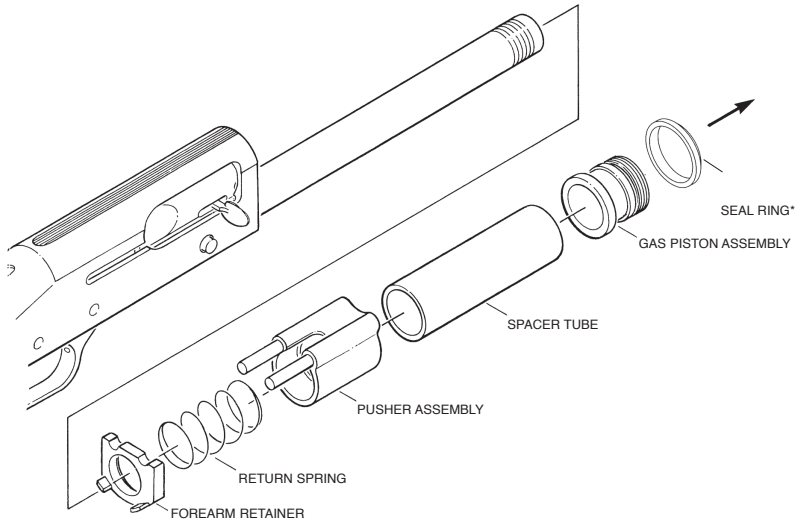

Figure 9

GAS SYSTEM REMOVAL

Remove the seal ring*, gas piston assembly, spacer tube, pusher assembly, gas system return spring, and forearm retainer from the magazine tube (Figure 10). Note the orientation of the seal ring* for reassembly. The angled surface of the seal ring* must face outward.



*Seal ring is not used in all models

Figure 10

GAS PISTON ASSEMBLY DISASSEMBLY

1. Insert a flat head screwdriver between the inner and outer gas rings to the left of the split in the outer gas ring (Figure 11).
2. Use the screwdriver to pry the outer gas ring away from the gas piston no more than 1/4" and hold it in this position.
3. Rotate the gas piston clockwise while holding the screwdriver stationary, this will peel both gas rings off of the gas piston.
4. Push inner gas ring out of the outer gas ring.

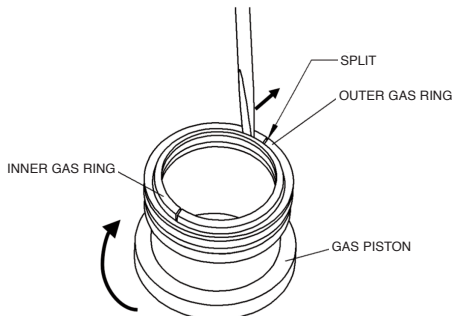

Figure 11

TRIGGER HOUSING ASSEMBLY REMOVAL

1. Push out the two trigger housing retaining pins using a punch no larger than 1/8" diameter (Figure 12). (The pins can be pushed out from either direction).
2. Remove the trigger housing assembly by pulling it straight out of the receiver.

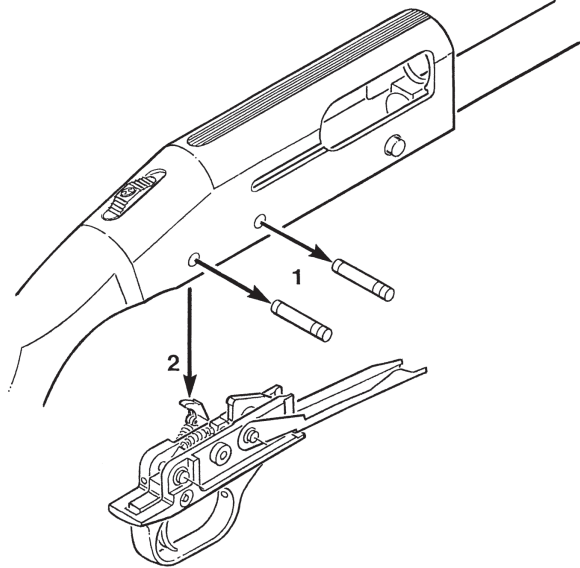

Figure 12

The trigger housing assembly is a complex assembly and must not be disassembled. Disassembly should only be performed at an authorized Product Service Center or by a qualified gunsmith.



Do not pull the trigger and allow the hammer to fall when the trigger housing assembly is removed from the receiver. To do so may result in personal injury or damage to the assembly.

ACTION REMOVAL/DISASSEMBLY

1. Pull the operating handle straight out of the bolt (Figure 13).
2. Remove the bolt and slide assemblies from the receiver through the barrel hole.
3. Remove the bolt from the slide.
4. Push the link pin out with a punch no larger than 1/8" diameter.
5. Remove the link.

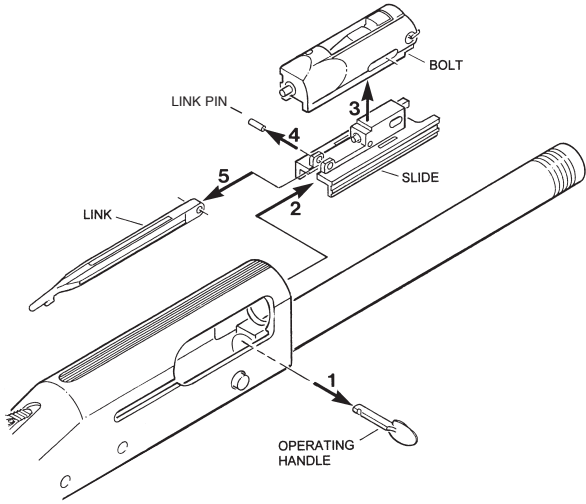

Figure 13



Field disassembly is now complete. The firearm should not be disassembled any further for routine cleaning or maintenance. Further disassembly should only be performed at an authorized Product Service Center or by a qualified gunsmith.

CLEANING AND LUBRICATION

With proper maintenance and care, your Mossberg® firearm will provide you with years of dependable service. Your firearm should be inspected and cleaned periodically to ensure that it remains in good condition. Clean your firearm as soon as possible after use. This is especially important if your firearm has been exposed to moisture. For maximum performance and continued satisfaction with your firearm, periodic cleaning and lubrication are essential.

Follow the instructions and use the equipment provided with a quality gun cleaning kit.



Always be sure that the safety button is fully rearward in the “ON” (SAFE) position (Figure 1) and that the firearm is unloaded by visually and physically checking the chamber, elevator, and magazine tube before cleaning your firearm. Wear eye protection during cleaning to protect your eyes from oil spatter or spring loaded components.

Normal use requires only that the mechanisms be free of excessive shooting residue. Very little lubrication other than a light oiling of internal and external surfaces to prevent rust is needed.

To ensure optimum performance, Mossberg recommends thorough cleaning of your firearm after every 200 rounds. However, unusually dusty, dirty, or harsh weather conditions, or use of ammunition which leaves significant powder residue may require more frequent cleaning.

If the firearm is to be stored for a long period of time, it should be thoroughly cleaned and oiled. Do not plug the barrel or store in a fabric-lined case that will absorb lubricant from the firearm, as this may result in corrosion to the unprotected metal surfaces.

Over-lubrication should be avoided during below freezing conditions. Many lubricants thicken in low temperatures which could affect the operation of the firearm. Exposure to unfavorable weather, or moisture from condensation requires additional care to prevent corrosion of the firearm.

BARREL CLEANING

Scrub the bore and chamber with solvent and follow with cleaning patches until the barrel is clean. A final pass with a lightly oiled patch will provide a protective coating. A stiff brass bristle brush is useful for removing stubborn deposits.



Be sure not to leave cleaning patches, excessive oil or grease in the bore as they can create dangerous obstructions, resulting in damage to the firearm and/or serious injury or death to you or those around you.

ACTION CLEANING

Clean all components of the action including the bolt, slide, and link (Figure 12) to remove accumulated residue. An evaporating solvent should be used. Action parts will remain cleaner, longer, if lubrication is used sparingly.

RECEIVER CLEANING

Clean the inside of the receiver with a rag or soft brush, giving special attention to the tracks which guide the bolt and slide. Place a few drops of light oil in these tracks when clean. Care should be taken when cleaning the exterior surfaces of the receiver to prevent cosmetic damage. Never use a brush with metal bristles, as this could remove the protective coating on the receiver.

TRIGGER HOUSING CLEANING

Brush loose residue from the trigger housing with a soft bristle brush. Never use a brush with metal bristles, as this could remove the protective coating on the trigger housing.



Never pull the trigger while the trigger housing is removed from the receiver, as damage to the trigger housing or personal injury may result.

GAS SYSTEM CLEANING

The gas system includes the magazine tube, seal ring*, gas piston assembly, spacer tube, gas system return spring, and gas cylinder portion of the barrel (Figure 17). These parts should be thoroughly cleaned using solvent. A stiff brass bristle brush is useful for removing stubborn deposits.

Remove deposits from the magazine tube, spacer tube, and gas system return spring.

Thoroughly clean all components of the gas piston assembly. Remove deposits from the inside and outside of both gas rings and the gas piston. An evaporating solvent should be used. It is critical that these components are free of deposits to ensure proper function of your firearm.

Using a stiff brass bristle brush, thoroughly clean the inside of gas cylinder portion of the barrel, making sure to remove all deposits to ensure that the gas piston assembly is able to reciprocate fully when firing. An evaporating solvent should be used.

Apply a light coat of gun oil to all metal parts and then wipe thoroughly with a dry cloth. Excess oil will accelerate the build up of carbon residue in the gas system and may have a negative effect on the firearm's performance.

Camouflage firearms: Caution should be exercised to avoid exposure of camouflage patterns to strong solvents or insect repellants.

*Seal ring is not used in all models.

For a detailed instructional video on how to disassemble, clean and re-assemble your Mossberg 930 firearm presented by Jerry Miculek go to www.mossberg.com/mossberg-930-complete-cleaning-and-disassembly-with-jerry-miculek/.

ACTION RE-ASSEMBLY

1. Position the link in the slot in the rear of the slide (Figure 14).
2. Attach the link to the slide with the link pin. The link must be installed with the tab side facing down.
3. Place the bolt on top of the slide, making sure it sits flat.
4. Install the bolt and slide assembly into the front of the receiver, link first. The slide may need to be “wiggled” side to side in order to engage the tracks in the receiver. The bolt will stop when it is nearly flush with the front of the receiver. While aligning the end of the link with the return spring plunger, press the bolt release. This will allow the action to seat in the receiver. The end of the link must be in the return spring plunger! Push the bolt rearward into the receiver just far enough for the operating handle slot to become fully visible.
5. To install the operating handle, first ensure the safety button is fully rearward in the “ON” (SAFE) position. Next, hold the operating handle with the notch facing rearward and push the handle through the bolt into the slide assembly. Push the operating handle inward until the plunger engages with the notch in the operating handle. Gently tug outward on the operating handle to ensure it is securely engaged in the bolt. The operating handle will now prevent the action from coming out of the receiver.

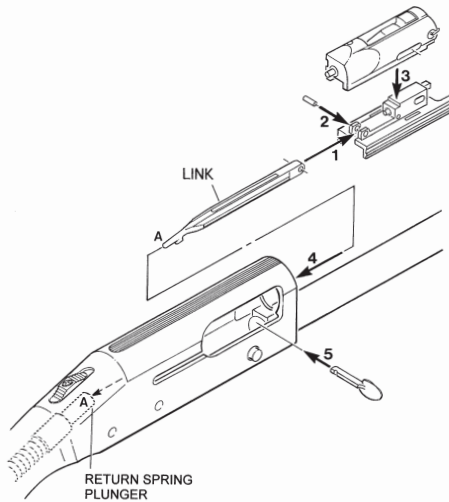

Figure 14

TRIGGER HOUSING ASSEMBLY RE-ASSEMBLY

1. Insert the trigger housing assembly into the receiver and align the two trigger housing retaining pin holes (Figure 15).
2. Push in the trigger housing pins until they are flush with the sides of the receiver.

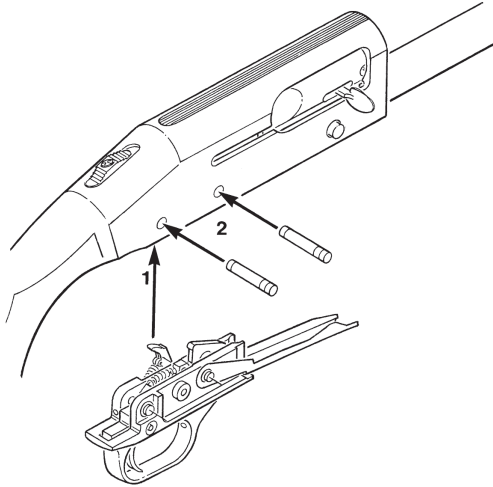

Figure 15

GAS PISTON ASSEMBLY RE-ASSEMBLY

1. Align the tapered end of each gas ring facing upward.
2. Place the outer gas ring over the inner gas ring, align the splits in the gas rings to be opposite each other then press them together. Make sure that that the tapered end of each gas ring is facing upward.
3. With the tapered ends of the gas rings facing upward, press one side of the gas rings down onto the gas piston, then press down around the rim to secure the gas rings to the gas piston (Figure 16).

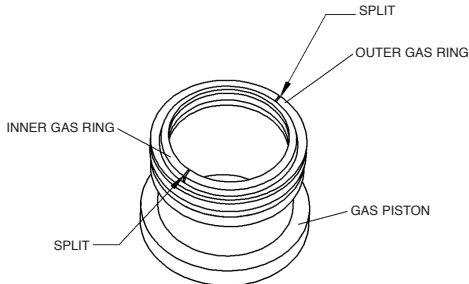

Figure 16

BARREL AND GAS SYSTEM RE-ASSEMBLY



Barrels are not interchangeable between model numbers, gauge or capacity. 930™ and 935™ model barrels are interchangeable only with barrels of the same model, gauge and capacity.

1. Grasp the operating handle and lock the action in the “OPEN” position (Figure 17).
2. Install the forearm retainer, gas system return spring, pusher assembly, spacer tube, gas piston, and seal ring* onto the magazine tube. Note the orientation of the seal ring*. Angled surface of the seal ring* must face out.



When interchanging barrels (combo models) or reinstalling the original barrel onto the firearm, YOU MUST ensure that the gas piston and seal ring* are present on the magazine tube prior to installing the barrel (see Figure 17). If the gas piston and seal ring* are not present on the magazine tube, remove them from the gas cylinder portion of the barrel that was on the firearm previously and place them onto the magazine tube as shown in Figure 17. Failure to do so may result in a dangerous malfunction, damage to the firearm and injury to the shooter and other persons. The firearm’s owner must accept full responsibility for the correct reassembly and functioning of the firearm after any disassembly or replacement of parts.

3. Install the barrel into the receiver and over the magazine tube. Continue to push the barrel into the receiver until fully seated. If the barrel binds during assembly, slide the gas piston forward, toward the gas cylinder. This should allow the barrel to seat.
4. Install the forearm.

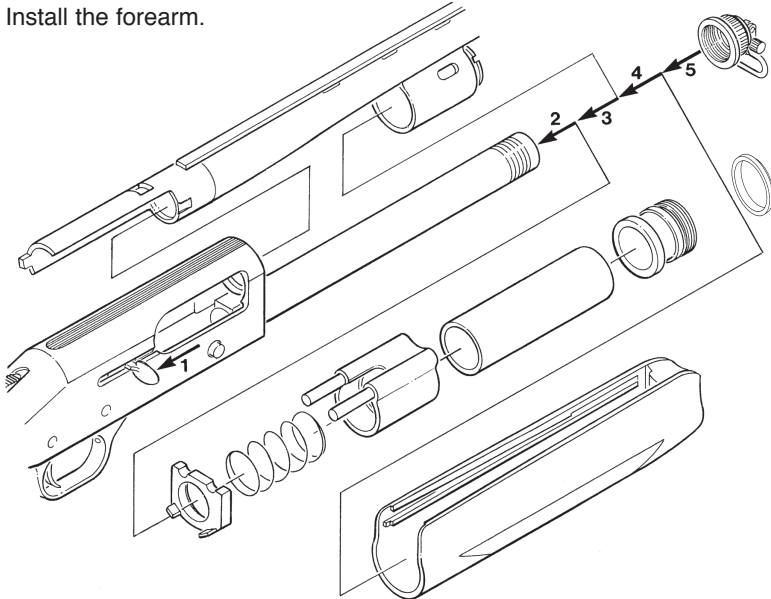

Figure 17

*Seal ring is not used in all models

5. Install the magazine cap. Tighten the cap hand-tight only.

FUNCTION TESTING



After performing any work on your firearm such as cleaning, disassembly, or installation of any accessory, check your firearm for proper functioning before firing any live ammunition.



Be sure the firearm is completely unloaded by visually and physically checking the chamber, elevator, and magazine tube.



KEEP THE MUZZLE POINTED IN A SAFE DIRECTION AT ALL TIMES THROUGHOUT THE FOLLOWING STEPS! FAILURE TO DO SO COULD RESULT IN SERIOUS INJURY OR DEATH TO YOU OR THOSE AROUND YOU IF THE FIREARM HAS NOT BEEN PROPERLY UNLOADED, AND FIRES WHILE YOU ARE TESTING ITS FUNCTION!

1. Move the safety button fully rearward to the “ON” (SAFE) position.
2. Grasp the operating handle and pull the bolt fully rearward. It should lock in the open position.
3. With fingers and other objects clear of the ejection port, press the bolt release and allow the bolt to move forward under spring pressure. It should lock in the fully closed position. Repeat this procedure several times to check for free movement of the action assemblies.
4. With the action closed and the safety button fully rearward in the “ON” (SAFE) position, pull the trigger fully rearward. The hammer should not fall (NO FIRE).
5. Remove your finger from the trigger. Move the safety button forward to the “OFF” (FIRE) position. The hammer should not fall (NO FIRE).
6. Leave the safety button forward in the “OFF” (FIRE) position.
7. Pull the trigger rearward. The hammer should fall (FIRE).
8. Open the action. Move the safety button rearward to the “ON” (SAFE) position.



IF YOUR FIREARM DOES NOT PERFORM AS DESCRIBED IN ANY OF THE ABOVE STEPS, CONTACT THE FACTORY AUTHORIZED PRODUCT SERVICE CENTER IMMEDIATELY. DO NOT ATTEMPT TO LOAD OR USE THE FIREARM.

SIGHT ADJUSTMENTS



BEFORE MAKING ANY SIGHT ADJUSTMENTS:

- a. Move the safety button fully rearward to the “ON” (SAFE) position and keep the muzzle pointed in a safe direction.
- b. Open the action, visually and physically check the chamber, elevator, and magazine tube to be certain the firearm is unloaded.

A. Williams-Style rear sights (slug models only):

Elevation may be adjusted by loosening the smaller of the two screws on the rear sight base. This will allow the sight leaf base to be raised or lowered by sliding the base up or down the rear sight ramp. Tighten the screw after adjustment (Figure 18).

Windage may be adjusted by loosening the larger of the two screws and sliding the sight leaf left or right in the sight base. Tighten the screw after adjustment (Figure 18).

Remember: Move the rear sight in the same direction you would like the shot to move. For example, if the point of impact is low and left of the point of aim, move the rear sight up and to the right.

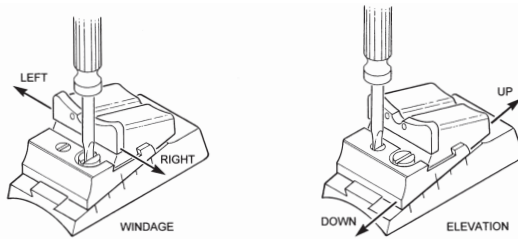

Figure 18

B. Turkey-Taker™ Fiber Optic sights (turkey models only):

Elevation may be adjusted by turning the screw, located on the rear sight, in or out. Turning the screw in (clockwise), will shift the point of impact up (Figure 19).

Windage may be adjusted by pulling up on the rear sight tab and swinging the rear sight to the left or right, locking in place in one of the three slots (Figure 19).

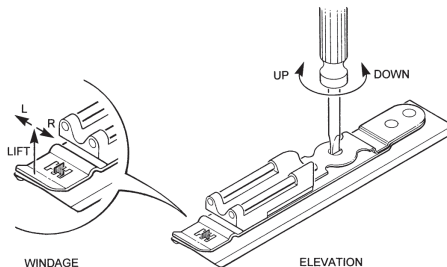

Figure 19

C. Ghost Ring® Rear and M16 Style Front Sights (SPX Models) =====

Elevation may be adjusted by turning the elevation screw, located on the rear sight, in or out. Turning the screw out (counterclockwise) will shift the point of impact up. The sight is also marked to show the “up” direction. Turning the screw in (clockwise) will shift the point of impact down (Figure 20).

Elevation may also be adjusted by turning the elevation screw, located on the front sight, in or out. Turning the screw out (counterclockwise) will shift the point of impact up. Turning the screw in (clockwise) will shift the point of impact down.

Windage may be adjusted by turning the windage screw, located on the rear sight, in or out. Turning the screw in (clockwise) will shift the point of impact to the right. The sight is also marked to show the “right” direction. Turning the screw out (counterclockwise) will shift the point of impact to the left (Figure 20).

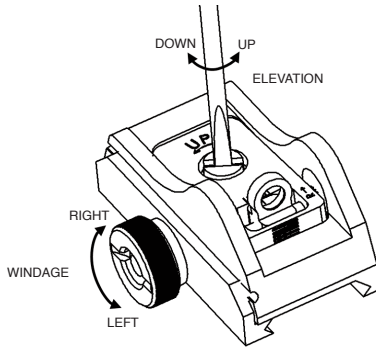

Figure 20

STOCK SPACER SYSTEM

Included with 930™ and 935™ shotguns (synthetic stock models only) is a matching set of stock spacers and stock retention plates. These spacers allow you to raise or lower the vertical position of the stock from 1/4" drop up to 3/8" rise. Each spacer and retention plate is marked with the amount of drop or rise they will provide (i.e., .250 DROP, .125 RISE, etc.). **In order to obtain the amount of drop or rise indicated on the spacer, the matching stock retention plate must be installed with the stock spacer.**

Stock Spacer Installation (Figure 21)



Move the safety button fully rearward to the "ON" (SAFE) position and visually and physically check the chamber, elevator, and magazine tube to be certain the firearm is unloaded. Wear eye protection during disassembly.

1. Remove the recoil pad (the screws will remain in recoil pad).
2. Remove the stock nut using a 3/4" socket wrench (Rotate counterclockwise).
3. Remove the stock nut spacer and the stock.
4. Remove the existing stock retention plate from the oval recess in the stock.
5. Place the selected stock spacer on the back of the receiver, text side facing out. (Note locking slot).
6. Reinstall the stock with the matching retention plate in the oval recess. **IMPORTANT: The retention plate must be installed with the text side facing out and right side up. (You should be able to read the markings right side up when looking into the butt end of the stock).**
7. Install the stock nut spacer and the stock nut. Do not over-tighten the stock nut.
8. Replace the recoil pad. Do not over-tighten the screws.

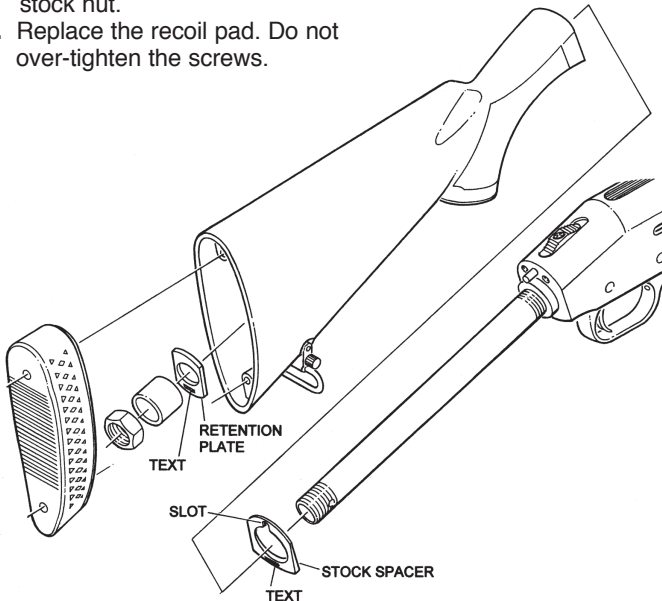

Figure 21



After performing any work on your firearm such as cleaning, disassembly, or installation of any accessory, check your firearm for proper functioning before firing any live ammunition.

CHOKE TUBES



BEFORE REMOVING OR INSTALLING ANY CHOKE TUBE:

Move the safety button fully rearward to the “ON” (SAFE) position and keep the muzzle pointed in a safe direction.

Open the action, visually and physically check the chamber, elevator, and magazine tube to be certain the firearm is unloaded.



Do not use bent or deformed choke tubes as these may result in tube or barrel damage upon firing which may cause serious personal injury to you or those around you. Inspect choke tubes periodically to insure they are properly installed and in good condition. Pay special attention to the threaded end of the choke tube to be certain it is not deformed or dented.



Never fire this firearm without a choke tube properly installed. Failure to do so will damage the precision threads on the inside of the barrel. Firing this firearm with loose choke tubes may lead to damage to the choke tube and barrel, as well as serious personal injury to you or those around you.

CARE & CLEANING: The precision threads on your choke tube should be kept clean and lightly oiled at all times.

During cleaning of the barrel, be certain a choke tube is properly installed. This will avoid residue build-up on threads.

ACCU-CHOKE™ TUBES (930™ MODELS ONLY)

ACCU-CHOKE™ tubes are designed for use with Lead, Steel, and other non-toxic shot. Each durable tube is clearly marked, as a guide, with the pattern it will produce.

TO REMOVE THE CHOKE TUBE: Loosen the choke tube with the choke wrench provided by turning it counterclockwise. When the choke tube is loosened, remove it completely with your fingers. Place the choke tube on a clean, dry surface.

TO INSTALL THE CHOKE TUBE: Screw the choke tube clockwise into the barrel by hand and then tighten the choke tube until snug using the choke wrench. Flush fitting choke tubes fit completely inside the barrel when properly installed. Do not use excessive force when installing.



Choke tube tightness should be checked periodically to avoid damage to the choke, firearm, and to prevent injury to you or those around you.

12 GAUGE ACCU-CHOKE™ TUBES (930™ Models only)

ITEM #	PATTERN*	ITEM #	PATTERN*
95190	FULL	95235	SKEET
95195	MODIFIED	95245	IMP. MODIFIED
95200	IMP. CYLINDER	95267	XX-FULL (Lead Shot Only)

* Lead, steel, and other non-toxic shot patterns will vary substantially depending on shell length, shot size, brand of ammunition, and the individual barrel. The shooter is urged to conduct pattern tests before field use.

ACCU-MAG™ CHOKE TUBES (935™ MODELS ONLY)

ACCU-MAG™ choke tubes are designed for use with Lead, Steel, and other non-toxic shot. Each durable tube is marked, as a guide, with the type of pattern it will produce.

TO REMOVE THE CHOKE TUBE: Loosen the choke tube with the choke wrench provided, by turning it counterclockwise. When the choke tube is loosened, remove it completely with your fingers. Place the choke tube on a clean, dry surface.

TO INSTALL THE CHOKE TUBE: Screw the tube clockwise into the barrel by hand and then tighten the choke tube until snug using the choke wrench. Flush fitting choke tubes fit completely inside the barrel when properly installed. Do not use excessive force when installing.



Choke tube tightness should be checked periodically to avoid damage to the choke, firearm, and to prevent injury to you or those around you.

12 GAUGE ACCU-MAG™ CHOKE TUBES (935™ Models only)

ITEM #	PATTERN*	ITEM #	PATTERN*
95256	SKEET	95254	FULL
95252	IMPROVED	95255	X-FULL
95253	MODIFIED	95257	ULTI-FULL (Lead Shot Only)

* Lead, steel, and other non-toxic shot patterns will vary substantially depending on shell length, shot size, brand of ammunition, and the individual barrel. The shooter is urged to conduct pattern tests before field use.



SLUGS: Because the 935™ Accu-Mag™ barrels are overbored, these barrels are for use with lead, steel, and other non-toxic shot loads only. We specifically disclaim any responsibility for damage or injury resulting from firing slugs (single projectile ammunition) through overbored barrels. Use only non-overbored 935™ barrels designed specifically for slug shooting.

ACCU-MAG™ ULTI-FULL™ TURKEY TUBE (935™ MODELS ONLY)

The NATIONAL WILD TURKEY FEDERATION has determined that the average distance at which turkeys are most effectively taken, under average environmental conditions and surroundings, is 30 yards.

Subsequently, Mossberg designed and manufactured this highly specialized choke tube for #4 or #6 lead shot to yield a high core concentration and high pellet count in a 20 inch circle at 30 yards. Shot patterns at distances greater than 30 yards will be less dense.

This special purpose “Turkey Tube” is specifically designed for use with Lead shot loads only.



Do not shoot steel shot through an Ulti-Full turkey tube as it may result in barrel damage.

Test results with the Ulti-Full™ Turkey Tube are averages and individual firearm performance may vary. Mossberg recommends pattern testing with several brands of ammunition at various distances to familiarize yourself with your firearm’s performance.

SERVICE INSTRUCTIONS

Should your firearm or any component of your firearm require service, ship your entire firearm (please do not send components only), via your chosen carrier, postage paid (we do not accept C.O.D. shipments), following these instructions:

- **Make absolutely certain your firearm is unloaded.**
- **Do not send ammunition with your firearm.**
- Remove all accessories from your firearm such as scopes, slings, scope mounts, etc.
- Ship your firearm in a suitable container, packaging it securely to prevent parts from shifting and/or damage during shipping.
- Include a note with a clear description of the service you wish us to perform, your complete return shipping address (no P.O. boxes please), your daytime telephone number and your e-mail address (if available). It is advisable to place your correspondence inside your shipping container when shipping.

SHIPPING ADDRESS

Product Service Center
Maverick Arms, Inc.
1001 Industrial Blvd.
Eagle Pass, TX 78853

If you have any service related questions, please contact the Product Service Center at (830) 773-9007 or service@mossberg.com

TO ORDER PARTS

To order parts from the Product Service Center, you can fax, phone, mail, or e-mail your order to one of the below numbers/addresses.

Fax Number: (830) 773-5893
Phone Number: (830) 773-9007
E-mail Address: service@mossberg.com
Mailing Address: Product Service Center
Maverick Arms, Inc.
1001 Industrial Blvd.
Eagle Pass, TX 78853
Attn: Order Department

Please provide your name, address, city, state, zip, your daytime phone number and e-mail (if available). The Product Service Center will need the Model Number, Serial Number, Gauge/Caliber, Finish, Item Number, and Part Name. There is a \$7.50 (U.S.) minimum parts order charge. Most major credit cards, money orders, and bank drafts are accepted.

Service outside of the U.S.A.

For Mossberg firearm parts and service requirements outside of the United States, customers are requested to contact the closest Mossberg stocking dealer/distributor.

MOSSBERG WARRANTY
930™ AND 935™ AUTO-LOADING SHOTGUN
TWO (2) YEAR LIMITED WARRANTY

Limited Warranty: O.F. Mossberg & Sons, Inc. ("Mossberg") warrants to you, the original retail purchaser of a new Mossberg® 930™ or 935™ Auto-Loading Shotgun (the "Mossberg firearm"), that the Mossberg firearm will be free of defects in material or manufacture for a period of two (2) years from the date of your purchase of the new Mossberg firearm (the "Warranty Period") in the United States or Canada. This is the only express warranty on the Mossberg firearm. MOSSBERG MAKES NO OTHER WARRANTIES OF ANY KIND OR CONDITIONS, INCLUDING, BUT NOT LIMITED TO ANY IMPLIED WARRANTY OF MERCHANTABILITY OR FITNESS FOR A PARTICULAR PURPOSE. This Limited Warranty gives you specific legal rights, and you may have other rights that vary from State to State.

Purchaser's Remedy: During the Warranty Period, Mossberg will, at its sole option, (1) repair the Mossberg firearm or any part thereof that, upon examination and testing by Mossberg, does not conform to the Limited Warranty without charge to you for parts or labor, or (2) replace the Mossberg firearm with a new or similar model. THIS REMEDY SHALL BE YOUR EXCLUSIVE AND SOLE REMEDY FOR ANY BREACH OF WARRANTY. MOSSBERG SHALL NOT BE RESPONSIBLE FOR ANY OTHER EXPENSES, LOSSES OR INCONVENIENCE THAT YOU MAY SUSTAIN AS A RESULT OF THE PURCHASE, USE, MALFUNCTION OR DEFECTIVE CONDITION OF THE MOSSBERG FIREARM. Mossberg reserves the right to inspect, examine and/or test the Mossberg firearm to assess any claim made under the Limited Warranty.

EXCLUSIONS: THIS WARRANTY DOES NOT COVER THE COSMETIC APPEARANCE OF THE MOSSBERG FIREARM OR ANY DAMAGE CAUSED BY:

- (1) NORMAL WEAR AND TEAR;
- (2) FAILURE TO PERFORM PROPER CARE AND MAINTENANCE;
- (3) ACCIDENTS, ABUSE OR NEGLIGENCE;
- (4) BARREL OR BORE OBSTRUCTIONS;
- (5) FAILURE TO FOLLOW THE INSTRUCTIONS AND WARNINGS THAT ACCOMPANY THE MOSSBERG FIREARM; OR
- (6) THE USE OF DEFECTIVE, NON-SAAMI STANDARD, REMANUFACTURED, HAND-LOADED, AND/OR RELOADED AMMUNITION.

IN ADDITION, ANY UNAUTHORIZED REPAIRS, ALTERATIONS OR MODIFICATIONS TO THE MOSSBERG FIREARM WILL AUTOMATICALLY VOID THE LIMITED WARRANTY.

LIMITATION OF DAMAGES: EXCEPT WHERE PROHIBITED BY LAW, MOSSBERG WILL NOT BE LIABLE FOR ANY LOSS OR DAMAGE WHATSOEVER ARISING FROM THE USE OF THIS MOSSBERG FIREARM, WHETHER DIRECT, INDIRECT, SPECIAL, INCIDENTAL, CONSEQUENTIAL OR PUNITIVE, REGARDLESS OF THE LEGAL THEORY ASSERTED, INCLUDING CONTRACT, WARRANTY, NEGLIGENCE, OR STRICT LIABILITY. SOME JURISDICTIONS DO NOT ALLOW LIMITATIONS ON HOW LONG AN IMPLIED WARRANTY LASTS, OR THE EXCLUSION OF INCIDENTAL OR CONSEQUENTIAL DAMAGES, SO THE ABOVE LIMITATIONS MAY NOT APPLY TO YOU.

Warranty Service: To obtain service under this Limited Warranty, you must follow the instructions found in the "Service Instructions" section of the Owner's Manual and return the Mossberg firearm to the authorized Product Service Center. You are responsible for all shipping costs to the Product Service Center. Mossberg will not accept COD shipments of any Mossberg firearm for service. After repair or replacement, the Mossberg firearm or a similar model will be returned to you, return postage paid by Mossberg. If we replace the Mossberg firearm, we will keep the firearm that you returned to Mossberg.

Modification of Warranty: No agent, representative, distributor, or authorized dealer of Mossberg firearms has any authority to modify the terms or conditions of the Limited Warranty in any way. The Limited Warranty may only be modified in writing by an authorized officer of Mossberg.

THIS LIMITED WARRANTY IS EFFECTIVE JANUARY 1, 2003.

MOSSBERG MODEL 930™ and 935™ PARTS LIST

ITEM	DESCRIPTION	ITEM	DESCRIPTION
1	BARREL ASSEMBLY	22	FOREARM RETAINER
2	FRONT SIGHT	23	GAS SYSTEM RETURN SPRING
3	CHOKE TUBE	24	PUSHER ASSEMBLY
4	SLING SWIVEL ASSEMBLY (2)	25	GAS PISTON SPACER TUBE
5	MAGAZINE CAP ASSEMBLY	26	GAS PISTON ASSEMBLY
6	FOREARM	27**	SEAL RING
7*	RECEIVER ASSEMBLY	28	MAGAZINE SPRING RETAINER
8	TRIGGER HOUSING PIN	29	MAGAZINE CAP DETENT
9	STOCK PIN	30	MAGAZINE PLUG
10	RETURN SPRING RETAINER PIN	31	MAGAZINE SPRING
11	RETURN SPRING PLUNGER	32	MAGAZINE FOLLOWER
12	RETURN SPRING	33*	SLIDE ASSEMBLY
13	RETURN SPRING RETAINER	34	LINK PIN
14*	TRIGGER HOUSING ASSEMBLY	35	LINK
15	REAR SHELL STOP	36*	BOLT ASSEMBLY
16	FRONT SHELL STOP SPRING	37	OPERATING HANDLE
17	FRONT SHELL STOP	38	BUTTSTOCK
18	FRONT SHELL STOP PIN	39	STOCK RETENTION PLATE
19	REAR SHELL STOP PIN	40	STOCK NUT SPACER
20	SHELL STOP RETAINING CLIP	41	STOCK NUT
21	REAR SHELL STOP SPRING	42	RECOIL PAD
		43	RECOIL PAD SCREW (2)

*Items on parts list are reserved for qualified gunsmiths or authorized Product Service Center only.

**Seal ring is not used on all models

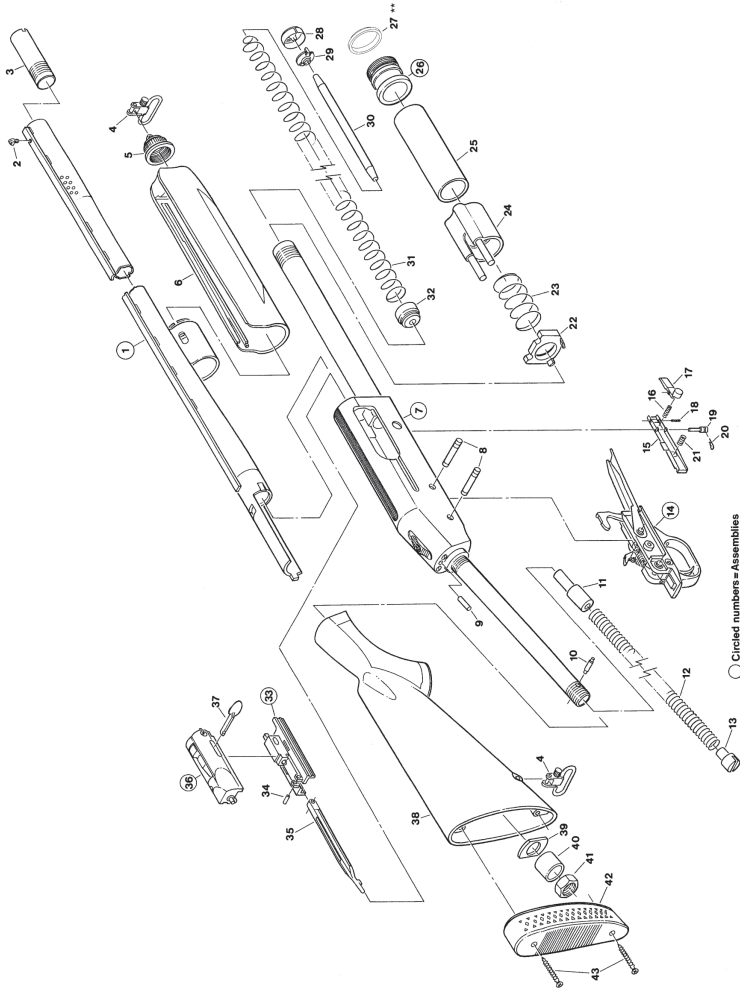

**Seal ring is not used on all models

NOTES

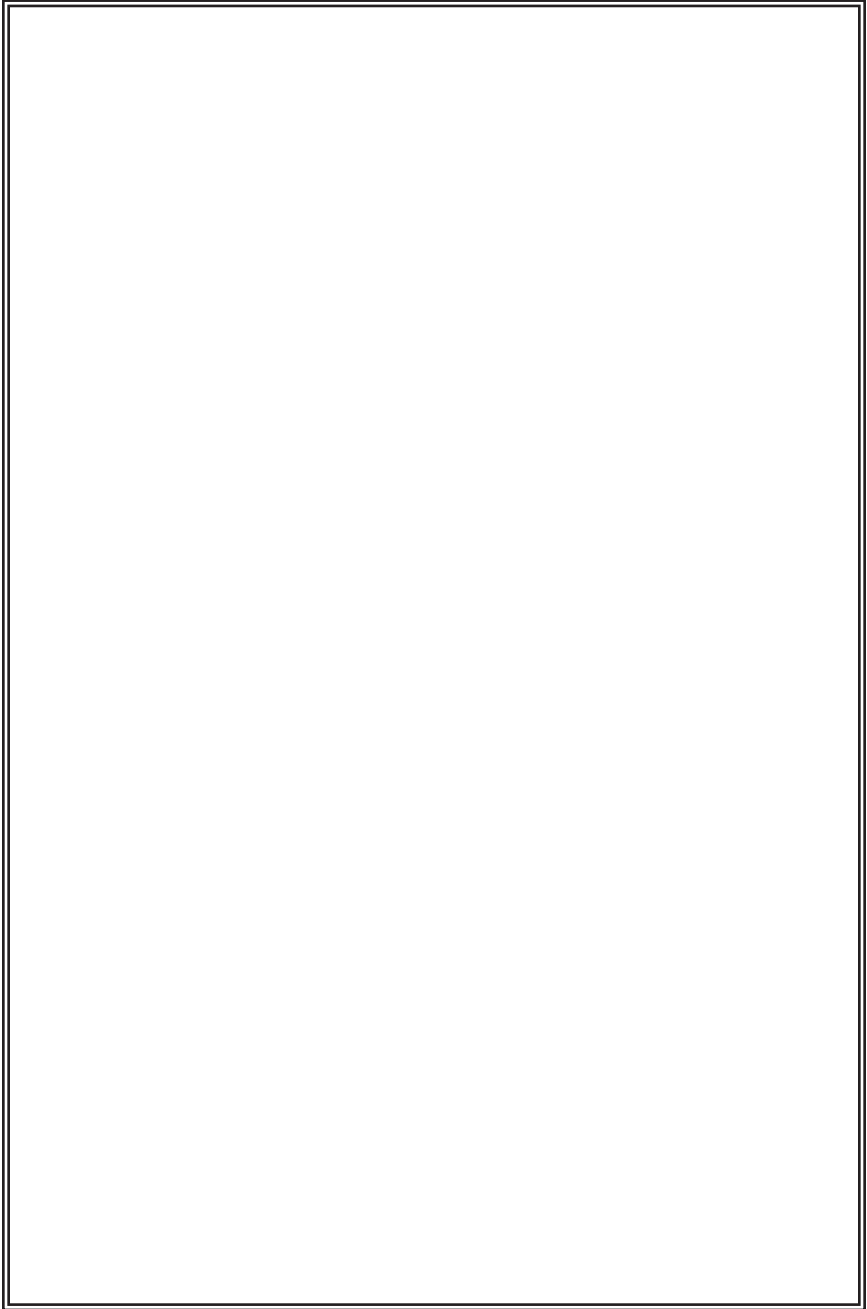

NOTES

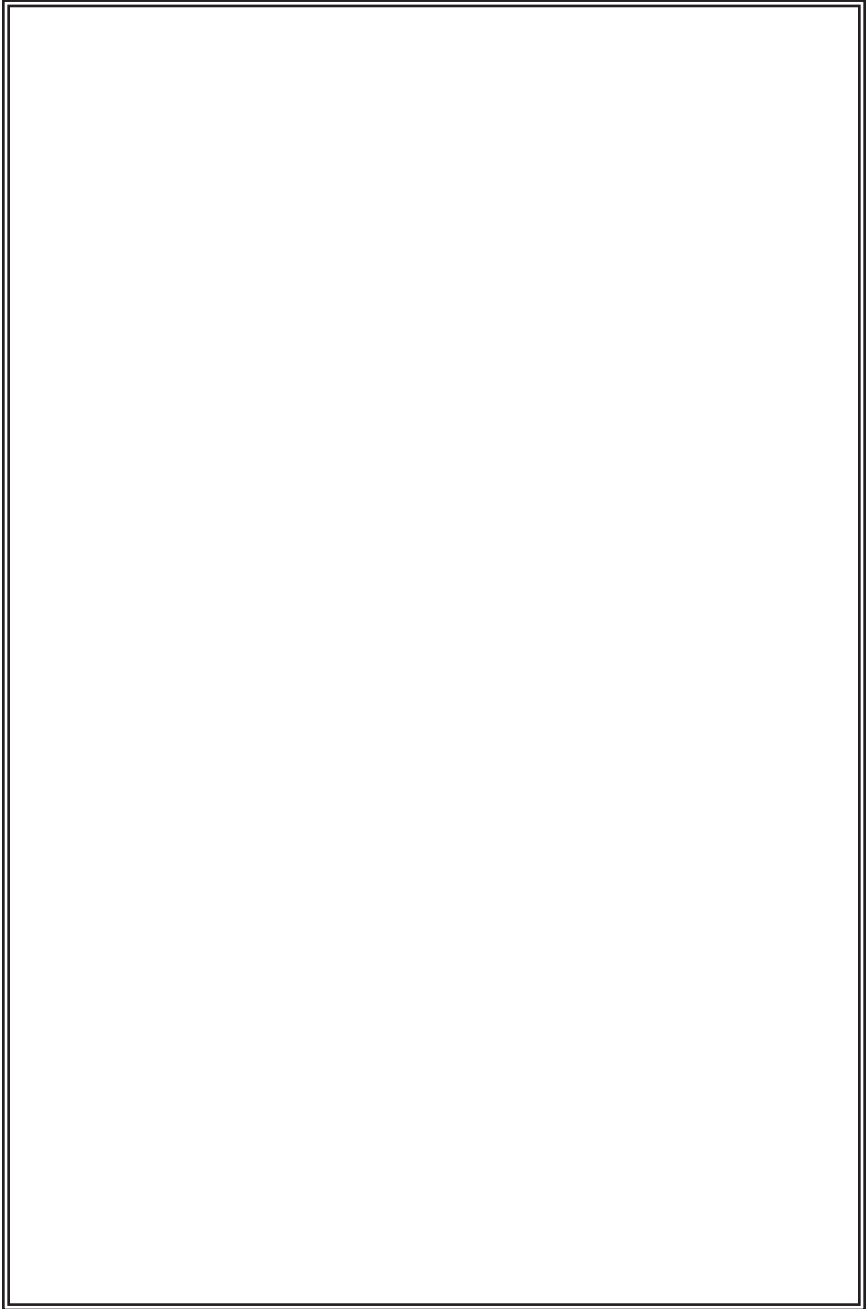

NOTES

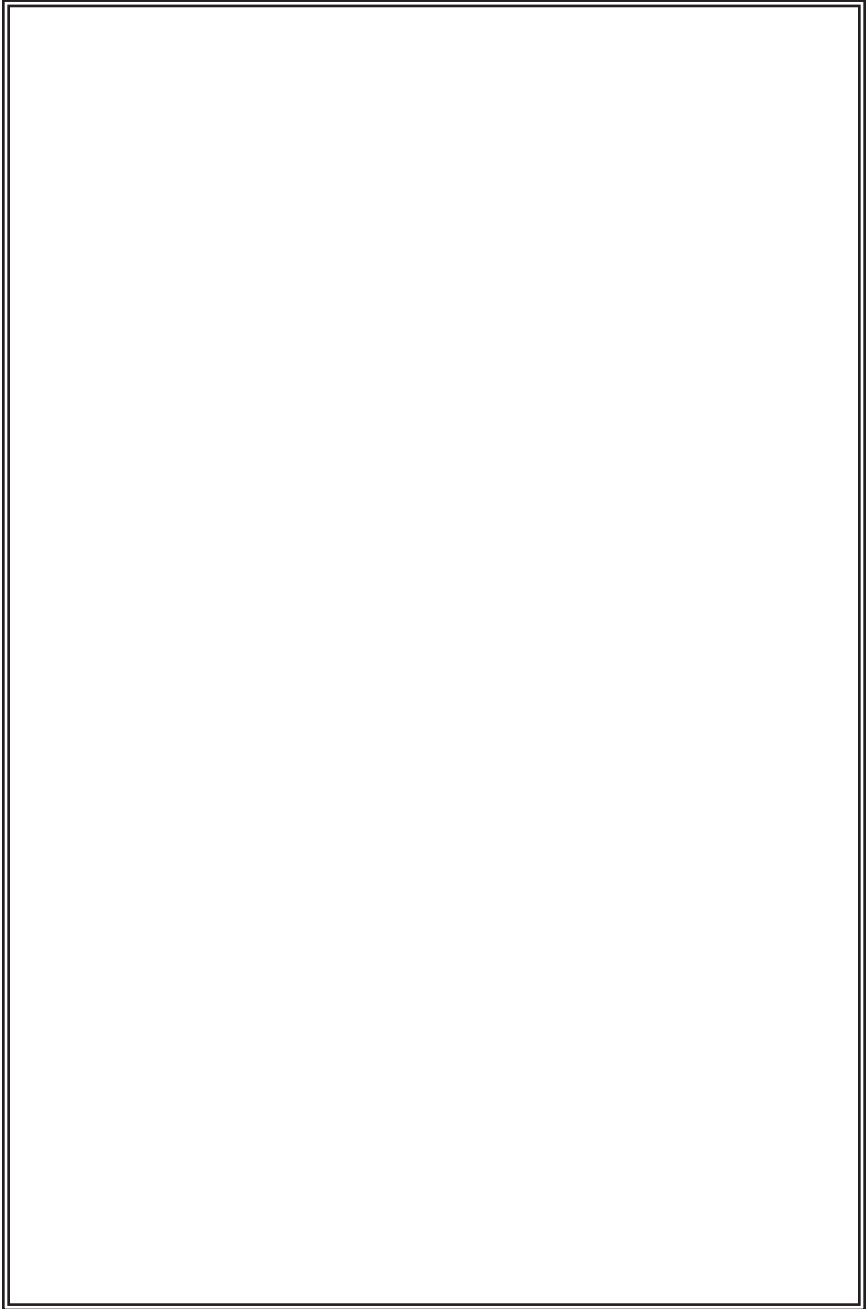
A large, empty rectangular box with a double-line border, occupying most of the page. It is intended for the user to write notes.

NOTES

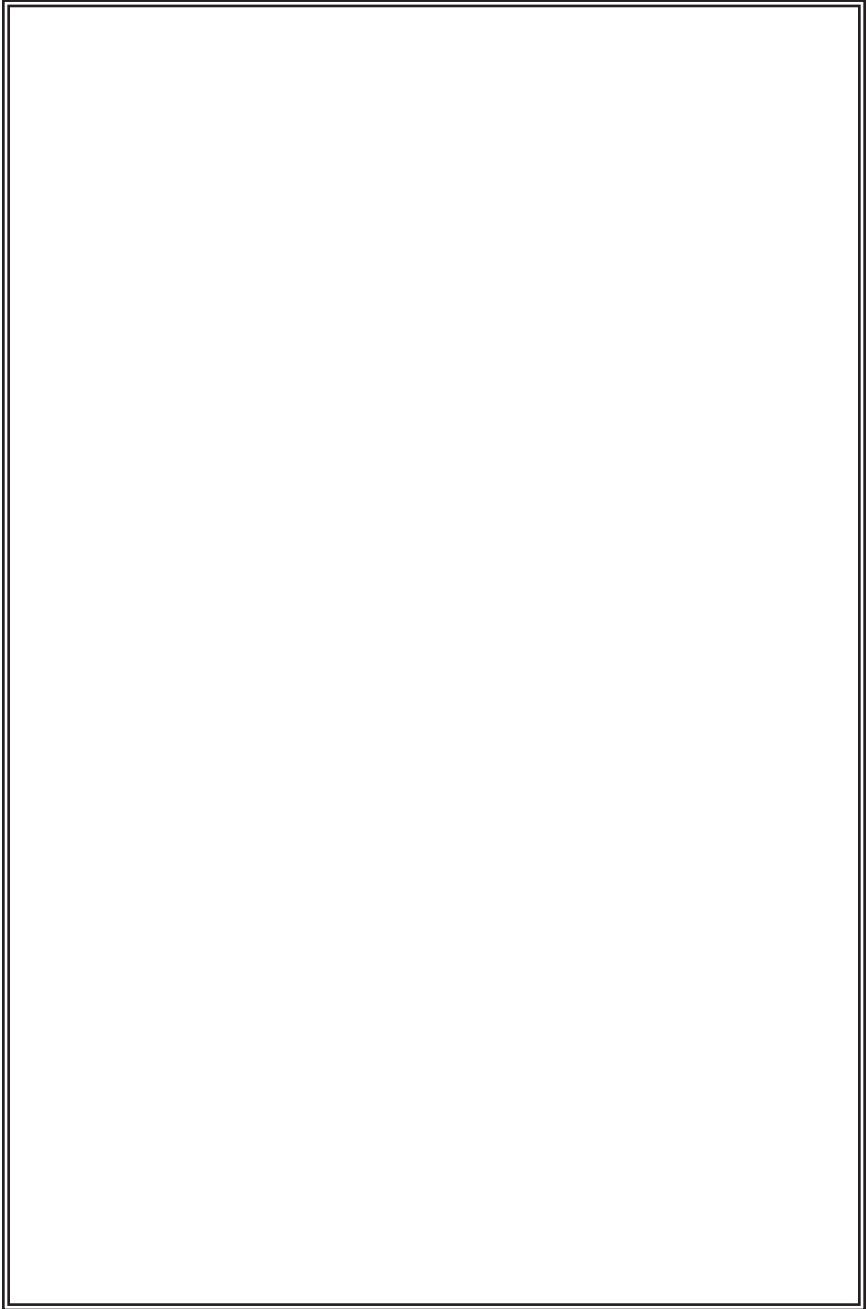

FIREARMS SAFETY DEPENDS ON YOU. MAKE NO MISTAKE ABOUT IT!

From the time an individual picks up a firearm, that individual shooter becomes a part of a system over which he has complete control. He is the only part of the system that can make a gun safe – or unsafe. Hunting and target shooting are among the safest of all sports. This booklet is intended to make them even safer – by re-emphasizing and reaffirming the basics of safe gun handling and storage and by reminding each individual shooter that he or she is the key to firearms safety. You can help meet this responsibility by enrolling in hunter safety or shooting safety courses. You must constantly stress safety when handling firearms, especially to children and non-shooters. Newcomers in particular must be closely supervised when handling firearms with which they may not be acquainted. Don't be timid when it comes to gun safety. If you observe anyone violating any safety precautions, you have an obligation to suggest safer handling practices, such as those in this booklet. Please read these rules carefully and follow the safety procedures outlined. Firearms safety is up to you. Make no mistake about it.

- 1. ALWAYS KEEP THE MUZZLE POINTED IN A SAFE DIRECTION**
- 2. FIREARMS SHOULD BE UNLOADED WHEN NOT ACTUALLY IN USE**
- 3. DON'T RELY ON YOUR GUN'S "SAFETY"**
- 4. BE SURE OF YOUR TARGET AND WHAT'S BEYOND IT**
- 5. USE CORRECT AMMUNITION**
- 6. IF YOUR GUN FAILS TO FIRE WHEN THE TRIGGER IS PULLED, HANDLE WITH CARE**
- 7. ALWAYS WEAR EYE AND EAR PROTECTION WHEN SHOOTING**
- 8. BE SURE THE BARREL IS CLEAR OF OBSTRUCTIONS BEFORE SHOOTING**
- 9. DO NOT ALTER OR MODIFY YOUR GUN, AND HAVE GUNS SERVICED REGULARLY**
- 10. LEARN THE MECHANICAL AND HANDLING CHARACTERISTICS OF THE FIREARM YOU ARE USING**

*Courtesy of
Sporting Arms and Ammunition Manufacturers' Institute, Inc.*